

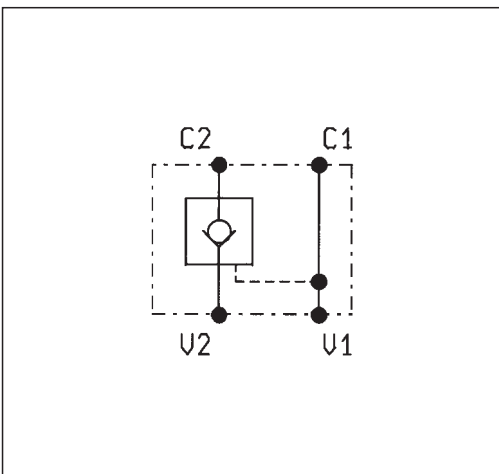

**UNIDIREZIONALI, SBLOCCAGGIO OLEODINAMICO,
SEMPLICE EFFETTO
PILOT OPERATED CHECK**

VSO-SE-DL-FCV

05.52.39 - X - Y - Z

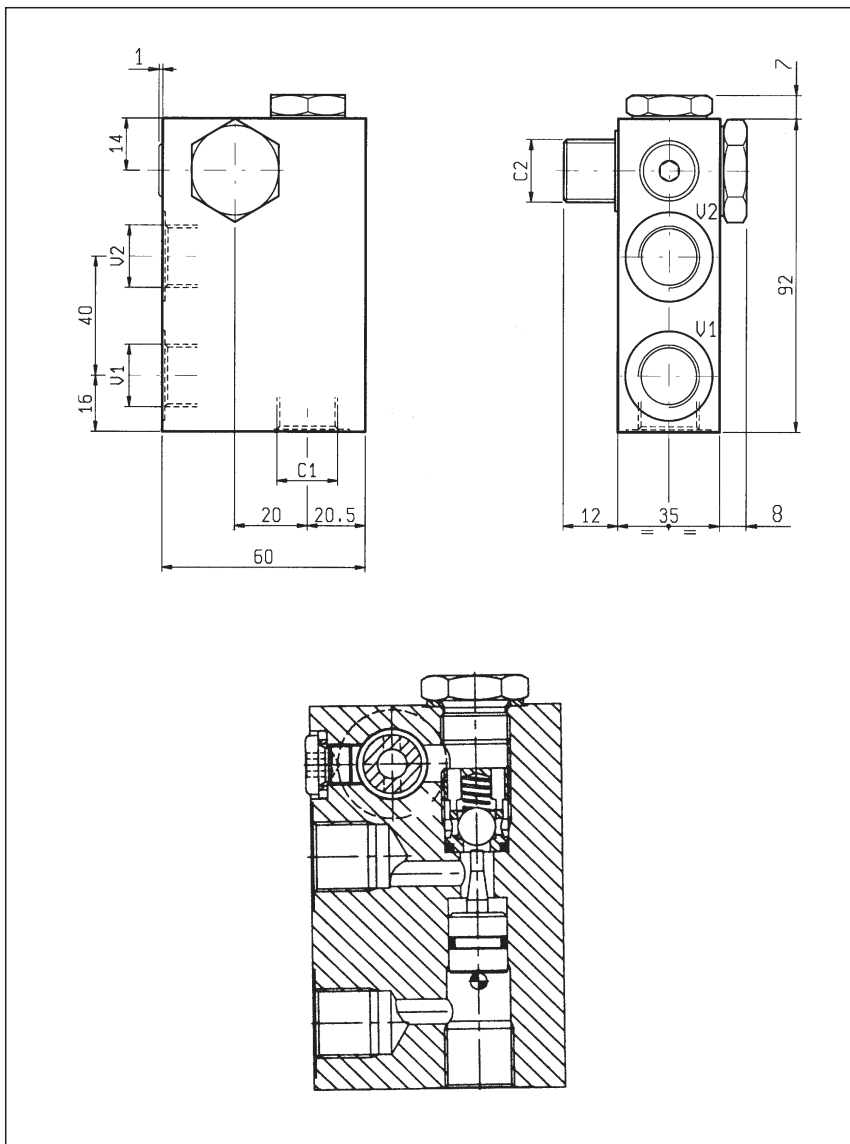

DATI TECNICI / TECHNICAL DATA	
Coppia di serraggio Installation torque	70-80 Nm (max 80°)
Pressione di lavoro max. Max. working pressure	350 bar
Portata max. Flow max.	30 l/min
Rapporto di pilotaggio Pilot ratio	4.6 : 1
Peso Weight	0.7 kg
<p>Per un funzionamento corretto scegliere il rapporto di pilotaggio in funzione della contropressione sulla linea di ritorno e del rapporto delle aree del cilindro.</p> <p>For correct operation the pilot ratio must be chosen as function of back pressure in the return line and of cylinder ratio.</p>	

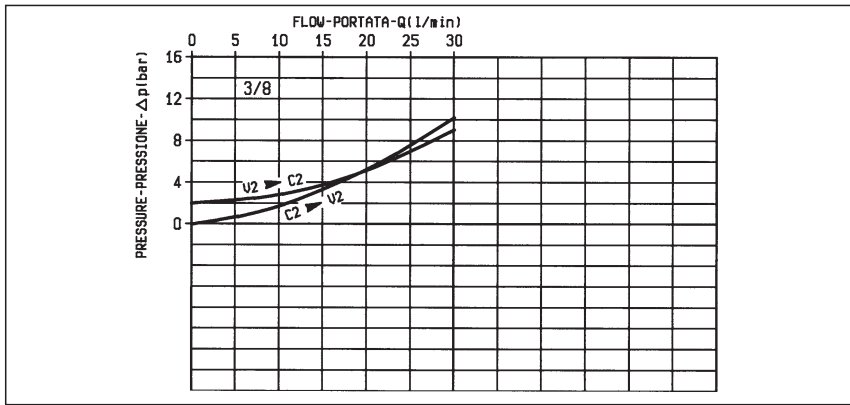

X	GUARNIZIONE SUL PISTONE DI PILOTAGGIO O-RING ON PILOT PISTON
10	con guarnizione with o-ring

Z	MOLLE / SPRINGS		
	Inizio apertura (bar) Cracking pressure (bar)	Cod. ordinazione Ordering code	Colore Colour
00	1	03.51.01.107	

Y	ATTACCHI / PORT SIZE
	V1-V2-C1-C2
02	G 3/8